

Owner's manual for

Venco 87mm & 100mm (3 1/2" & 4") De-airing Pugmill

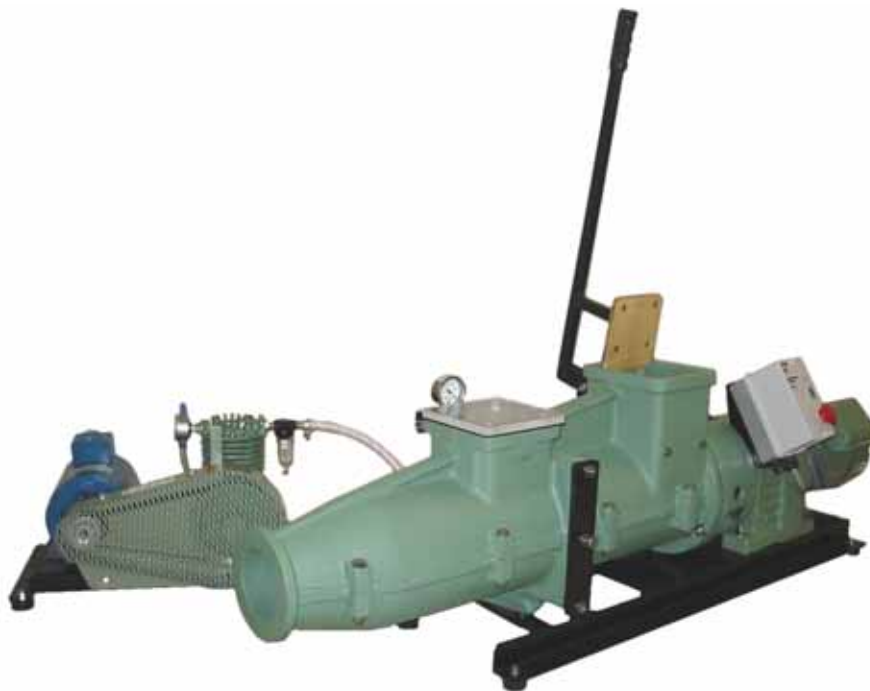

Venco Products

29 Owen Road Kelmscott, Western Australia 6111
ph +61 8 9399-5265 fax +61 8 9 497 1335
email: venwest@inet.net.au

www.venco.com.au

NOTES ON THIS MANUAL

The information given in this owner's manual applies to both the Venco 87mm (3 1/2 ") and 100mm (4") pugmills.

Tools required for assembly:

- 13mm (1.2") spanner
- 14mm (9/16) spanner
- flat blade screw driver
- 17mm (1 1/16") spanner
- small tin of multi-purpose grease

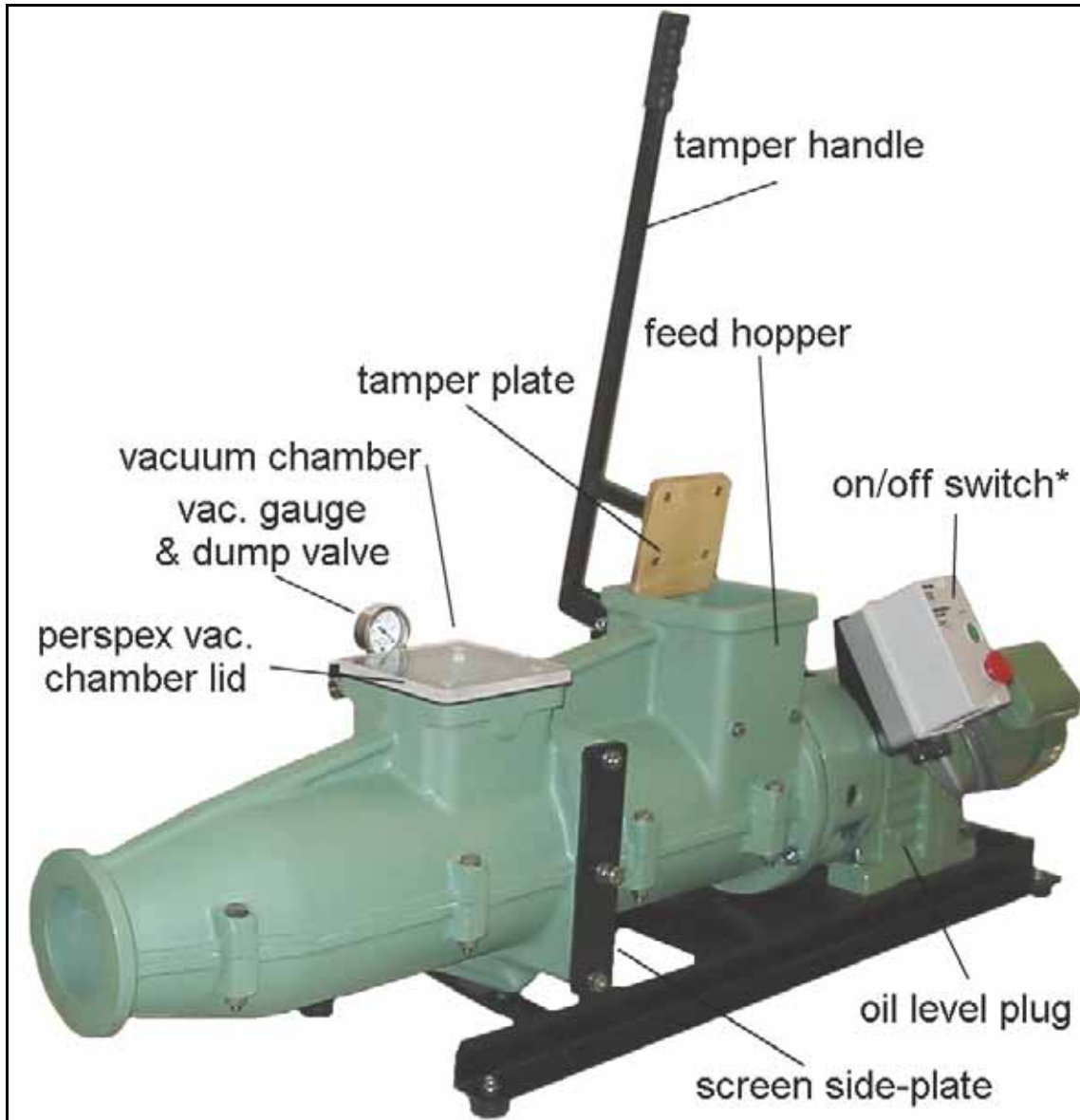

Figure 1: Components of the Venco 75mm pugmill (vacuum pump not shown)
[*the switch may vary depending on model]

UN-PACKING THE PUGMILL

Carefully disassemble the shipping crates and unbolt both the pugmill and vacuum pump from their wooden baseboards. Locate the rubber feet and fasten one to each corner of the pugmill frame and vacuum pump using a 13mm spanner.

The pugmill is insured for the unlikely event of damage during transport. Please report any damage to your supplier.

Important notes

- ❖ The pugmill should be placed on a sturdy table or bench approximately 500mm (20") high.
- ❖ The vacuum pump may be located up to 7 metres (20 ft) away from the pug.
- ❖ The electrical supply should be from a 220-240V, 50-60Hz, single phase 10 A outlet. Extension cords and any power boards should be rated at 15A (please check with your supplier for other voltages)

Hint: Venco use waterproof plywood for the shipping crate. This timber may be re-used to make long lasting batts for your potters wheel.

SETTING UP THE PUGMILL

Fitting the tamper handle

Remove the two nuts and washers protruding from the rear of the feed hopper, using a 13mm spanner. Fit the tamper lever bracket to these bolts and secure with the nuts and washers previously removed. See figure 2.

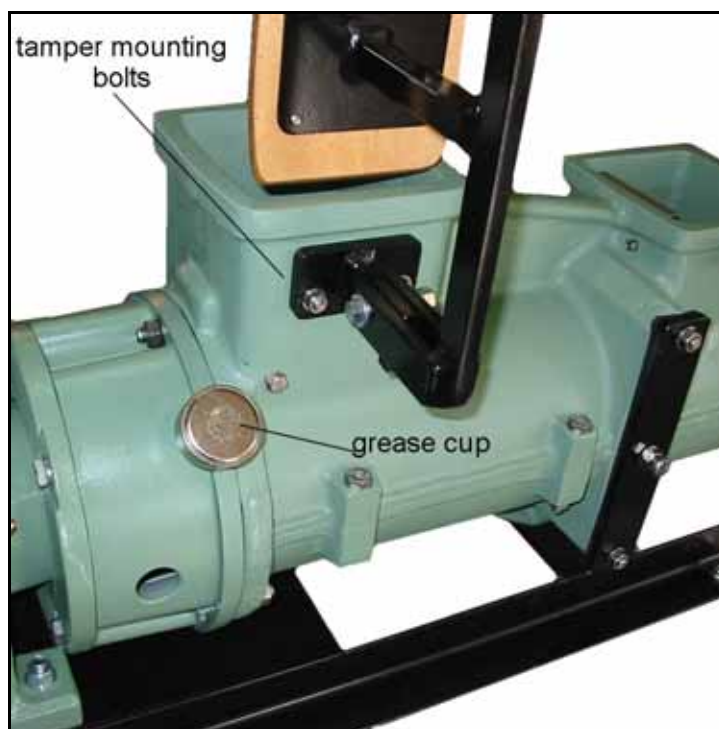

Figure 2: Attaching the tamper lever

Setting up the vacuum pump

Locate the following parts:

- ❖ vacuum hose, with two hose clamps
- ❖ vacuum pump filter / water trap
- ❖ vacuum gauge
- ❖ clear plastic, vacuum chamber cover with gasket
- ❖ spare vacuum chamber cover gasket (square shape)
- ❖ spare side-plate gaskets (shredder screen cover gaskets)

Important: It is recommended to smear a light film of grease onto the brass threads before attaching components. This aids sealing and future disassembly.

1. Screw the vacuum gauge onto the brass fitting attached to the rear of the pugmill's vacuum chamber. To tighten use a 14mm (9/16") spanner on the square brass section adjacent to the thread –do not over tighten. A layer of Teflon tape (plumber's thread tape) on the thread may make it easier to align the gauge as in Fig. 1.
2. Screw the filter / water trap onto the brass fitting on the cylinder of the vacuum pump. The clear bowl should be facing downward. See Fig 3.
3. Connect the vacuum hose using the hose clamps supplied to both the filter and the fitting adjacent to the vacuum gauge on the pugmill.
4. Fit one of the vacuum chamber gaskets onto the posts of clear plastic cover. Place the cover on the vacuum chamber. See Fig 1.

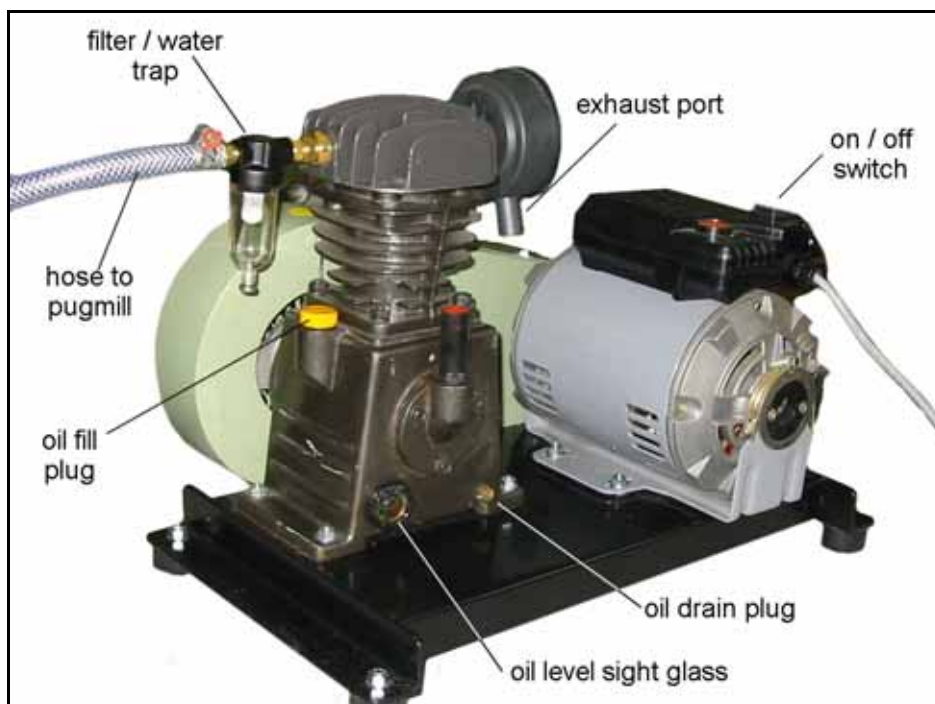

Figure 3: Components of the vacuum pump

OPERATION

Loading the pugmill

It is recommended that the feed hopper is loaded with clay about tennis ball size. These should be fed into the hopper onto the side where the blades pull the clay down into the barrel.

Hint: Each lump of clay should be tamped down with the lever before loading the next piece.

Operator effort is greatly reduced by continually loading and tamping small pieces of clay rather than completely filling the hopper.

With experience, dry powder clay can be blended with wet clay to produce a homogeneous mixture.

- ❖ The pugmill and vacuum pump motors are fitted with overload protection. If either unit trips off, wait for the motor to cool and then press the red reset button located near the rear of the motor.
- ❖ When the pugmill is not in use, seal the hopper and nozzle with a plastic bag. This may be made airtight by using an elastic band or some adhesive tape.
- ❖ Clean out all of the clay if the pugmill is not to be used for over a **month**. *See maintenance section.*

❖ Leave the vacuum pump running continuously while pugging. The pugmill itself may be turned on and off as required. (If the vacuum pump is turned off during pugging, the clay within the barrel may absorb air.)

❖ There is a small slot in the vacuum chamber, through which air is drawn away from clay inside the barrel. It is normal for some of the clay to be sucked up through the slot and into the vacuum chamber during operation. This clay need only be removed if the chamber becomes full.

To successfully de-air clay, there need only be a small hole from the vacuum chamber into the pugmill barrel.

Hint: The de-airing slot can be cleared swiftly by quickly flicking the vacuum dump tap on and off.

- ❖ For satisfactory de-airing the vacuum gauge should read 90kPa or more. 95-98kPa is ideal.
- ❖ Some fine porcelain type clays are difficult to de-air. To improve de-airing, slow the rate of flow by blanking off the top of the shredding screens. This may be accomplished by applying a layer of plastic adhesive tape to the top layer of the screen. See figure 4. This technique may also be used to reduce the clay flow through the slot into the vacuum chamber if this becomes a problem with softer clays. Install with the blanked area immediately beneath the vacuum chamber. Do not blank off more than 50mm (2") of screen height. *See the maintenance section for information on removing the shredding screen.*
- ❖ It is important to check the vacuum pump oil level and condition weekly. *See the maintenance section for more information.*



Figure 4: Blanking off the shredder screen to reduce production

(Important –Install with mesh / tape facing the motor)

MAINTENANCE

Pugmill maintenance

Venco pugmills are designed to be extremely robust and should reward you with many years of trouble free operation. To ensure this please follow these few simple procedures.

Important before performing any maintenance turn-off the pugmill and unplug the power supply cable.

Lubricating the auger seal

An auger seal is fitted to prevent any clay back feeding into the auger thrust bearing. This seal requires greasing after every 50 hours operation. A grease cup is fitted on the rear side of the pugmill –see figure 2. Sufficient grease is injected with half a clockwise turn of this cup.

If this cup is fully screwed in, the cup may need to be re-filled. Remove the cup by fully unscrewing it (anti-clockwise), and fill with multi-purpose grease.

Checking/changing gearbox oil

The pugmill gearbox is filled with high quality industrial gear oil. Under normal conditions this need to be changed after 10-15,000 hours operation. When the pugmill is used for one to two hours per day, change the oil after 10 years service. Use gear oil with a viscosity class of ISO VG220. (Shell Omala 220, BP Energol GR-XP 220, Texaco Meropa 220, Mobilgear 630)

To drain the gearbox, remove the lowest plug adjacent to the gearbox foot. Use a 5mm hex key to remove the gearbox plugs. To fill the gearbox, firstly remove the oil level plug located approx. 50mm (2") up the side of the gearbox from the black base. See figure 1. Fill via either of the top two filling plugs until oil starts to run from the open level plug.

Disassembling the barrel.

It may be necessary to occasionally split the barrel for cleaning. To do this, remove the single nut located at the rear of the feed hopper and the eight bolts around the barrel seam.

Carefully pry the two halves apart, taking care not to scratch the mating surfaces of the barrel halves.

Shredder Screen removal

A pair of stainless steel shredding screens are mounted within the pugmill barrel. With use they may become blocked with grit or other impurities carried with the clay. A clogged screen results in reduced production and increased operator effort. If this occurs the screens should be extracted, washed and re-installed.

First remove the two screen side plates (black) by removing the nuts at either end of the plate, with a 17mm (11/16") spanner. Do not remove the central screw, as these are pre-adjusted to centralise the screen pair. Once the side plates have been removed attach the screen removal tool to the screens with the bolts provided. Pull or lever out the extractor handle to remove the screens.

Re-assembly is simply the reverse of above. Ensure the gasket is fitted to the studs before fastening the side-plates. A thin layer of grease on the gasket will aid sealing and future disassembly.

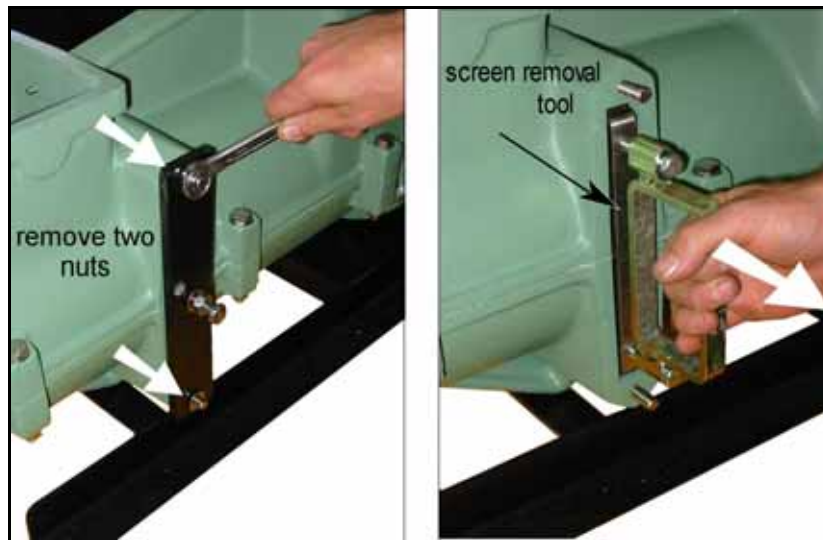

**Figure 5: Removing the shredder screen
(shredding mesh installed with mesh facing towards the motor)**

Hint: An optional coarse shedding screen is available for use with coarse terracotta or clay containing large amounts of grog.

Re-assembling the barrel

Carefully clean and dry the mating surfaces of the two barrel halves. Apply a length of gasket tape along each length of the barrel flange, of one barrel half. An original barrel gasket may be obtained from your supplier, or alternatively two layers of ordinary electrical insulation tape makes a satisfactory gasket.

Hint: Before re-assembling the barrel, smear all bolts with a layer of multi-purpose grease. This minimises corrosion and eases future disassembly.

Note: It is not recommended to use silicone or similar gasket sealants to seal the barrel halves. This type of gasket makes it difficult to split the barrel in future.

Vacuum pump maintenance

It is important to check the vacuum pump oil level **weekly**. As the pump operates some oil is carried past the piston rings and exhausted. This is normal and beneficial in keeping the plate valves lubricated and free from corrosion.

Exhausted oil may be collected and re-used. If you wish to do this, connect a short flexible hose to the exhaust port and place the other end into a container. Be sure to keep this oil free from grit or dust contamination.

The vacuum pump has a sight glass, to check the oil level. Ensure oil level is up to the mark indicated on the clear window.

Top up with SAE30, SAE 40 or multigrade 20/40 engine oil. DO NOT use friction-modified oils. The vacuum pump filter/water trap should be checked occasionally. Clean and drain, by unscrewing the clear plastic bowl. Apply a thin layer of grease or petroleum jelly to the thread on the bowl to aid sealing and future disassembly.

Hint: Some clays shed water during the de-airing process. This can be carried back to the vacuum pump as vapour. This mixes with the sump oil, turning it cloudy white. If this happens, drain the oil into a glass jar and replace with new oil. The old oil can be re-used after it separates from the water (the oil will float on top of the water).

TROUBLESHOOTING GUIDE

Symptom	Problem Description	Remedial Action
VACUUM PUMP milky / cloudy oil	water mixed with oil	drain oil from vacuum pump and replace with fresh oil. Contaminated oil will eventually separate and oil may be drained off and reused.
motor stops running	overload trip protection	check oil level in vacuum pump, wait for motor to cool before restarting if problem persists see your supplier
low/flickering vacuum	vacuum leak or vacuum pump problem	clay feed into pug too slow - increase feed rate <i>for more details see below.</i>
PUGMILL motor stops running high pitch squeal from rear of hopper area	overload trip dry auger seals (usually after 8-10yrs)	overloading the pugmill, wait for motor to cool before restarting (1) ensure grease cap is full, then screw in while operating until noise stops (2) remove grease cup and clear hole with a piece of wire then do step (1) above (3) if squeak persists, auger seals may need replacing flick vacuum dump tap open/close quickly to suck clay away clay too soft - change consistency flow rate too high - reduce speed by blanking shredder screen - see manual
excess clay being pushed into vacuum chamber	bridging of vacuum slot	remove and clean shredder screen Motor dry burnings will quickly block the screen - wet and ball before using
reduced clay output	blocked shredder screen	remove and clean shredder screen see manual for correct feeding method
hard to push clay into feed hopper air in clay	blocked shredder screen or incorrect feed method loss of vacuum <i>note: gauge should read more than 50KPa (at sea level)</i>	* vacuum pump must be operated continuously while pugging * Remove plastic vacuum chamber lid and place finger over brass inlet within vacuum chamber while pump is operating. If this restores vacuum reading on gauge then the problem lies with the vacuum chamber lid gasket or with the barrel gasket / screen side plate gaskets - see note (a) * Check all fittings for tension, remove and grease threaded connections * Check plastic vacuum chamber lid for distortion - order new lid * If after checking the above, it is possible that the vac. pump needs servicing <i>- please contact your dealer for advice. See note (b)</i>
Notes:		
(a) check condition of black gasket under vacuum chamber lid - replace if worn or damaged. Run a bead of soft clay along barrel seam while pugmill/pump operating. This may be cleaned after seal has formed.		
(b) A simple method of isolating and testing the vacuum pump alone is to fit the vacuum gauge directly to the inlet of the pump. This may be done by using additional fittings or a short piece of rubber hose (and two hose clamps). The gauge must be read in a vertical position.		

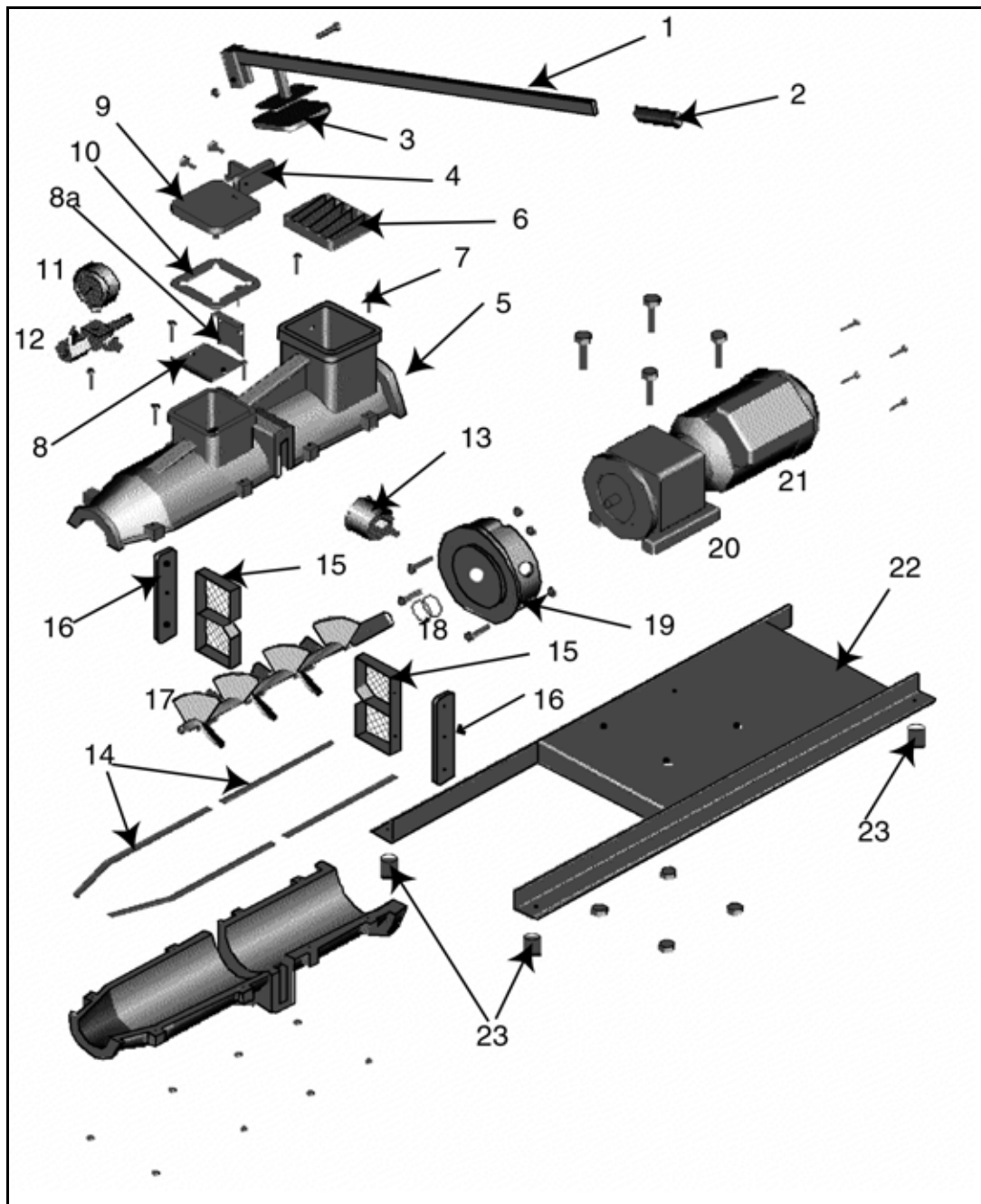

87mm & 100mm (3 1/2 & 4") Venco Pugmill Parts Diagram

- | | |
|---------------------------------------|---------------------------------|
| 1. Tamper handle | 2. Tamper handle grip |
| 3. Tamper handle wooden plate | 4. Tamper handle pivot assembly |
| 5. Barrel upper / lower | 6. Hopper safety grill |
| 7. Barrel seam bolts (x9) | 8. Vacuum chamber cover plate |
| 8a. Vacuum chamber scraper plate | 9. Vacuum chamber plastic lid |
| 10. Vacuum chamber lid gasket | 11. Vacuum gauge |
| 12. Vacuum dump assy. (tap & fitting) | 13. Grease injector cup |
| 14. Barrel gasket | 15. Shredder screens (x2) |
| 16. Screen side plates (x2) & gaskets | 17. Auger |
| 18. Auger O-ring seals | 19. Auger support assembly |
| 20. Gear box | 21. Motor |
| 22. Base assembly | 23. Rubber feet (x4) |

Other ceramics equipment available from Venco:



No.6 Cone drive potters wheel. High quality budget priced wheel with integrated seat.



No.3 Cone drive potters wheel.



No.5 Cone drive potters wheel with hand operated speed lock



No.7 High torque, electronically controlled potters wheel



75mm (3") , standard and de-airing pugmill



All stainless steel, high capacity de-airing pugmill with mechanical variable speed drive. 212 or 262mm (8 ½ or 10" barrel)

VENCO – world renowned for quality and reliability