

*Owner's Manual for*

# Venco

[www.venco.com.au](http://www.venco.com.au)

*direct  
drive*



## **Venco Products**

29 Owen Road Kelmscott, Western Australia 6111

Ph: +61 8 9399 5265 | Fax: +61 8 9497 1335

Email: [info@venco.com.au](mailto:info@venco.com.au)

**[www.venco.com.au](http://www.venco.com.au)**

Thank you for choosing the Venco Direct-drive pottery wheel. This wheel represents a combination of the latest in electronics technology and precision hand-constructed fabrication.

The heart of the Direct-drive is a powerful permanent magnet, brushless motor that is directly coupled to the wheel head. Being direct drive means there are **no belts** to tighten and no parts that will need maintenance. The motor is driven by an intelligent, computer based speed controller, which is also maintenance free.



**CAUTION:** As with all pottery equipment, it is advised to connect your wheel to an RCD (earth leakage detection) protected power supply.

**An earthed supply MUST be used.**



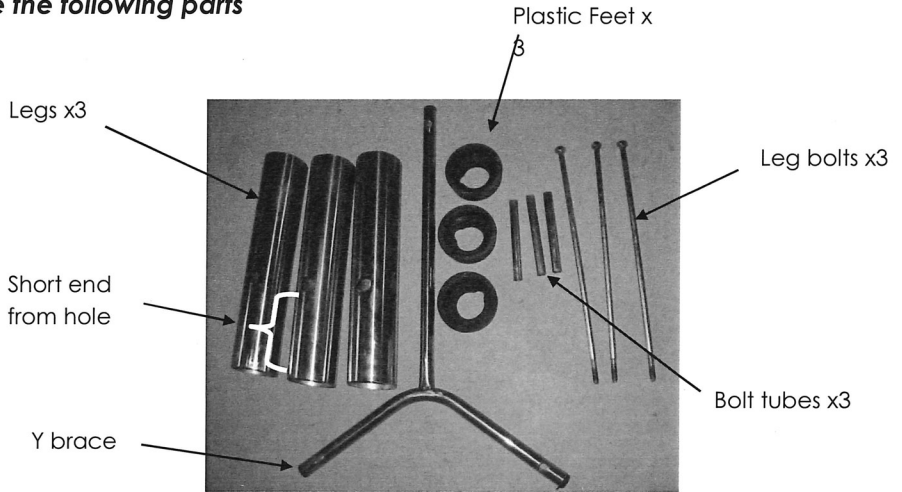
**Figure 1: Components of the VENCO Direct-drive**  
(Optional clip on tables shown)

# SETTING UP THE VENCO DIRECT-DRIVE

## Fitting legs for sit-down operation.

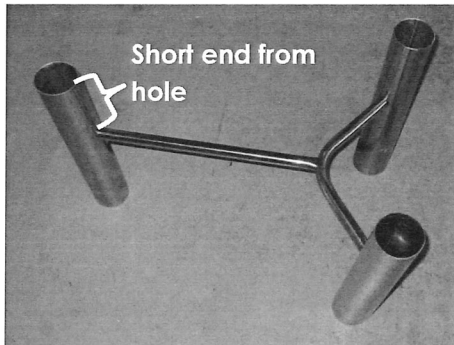
1) Turn the wheel upside down and place it on its tray.

### **Locate the following parts**



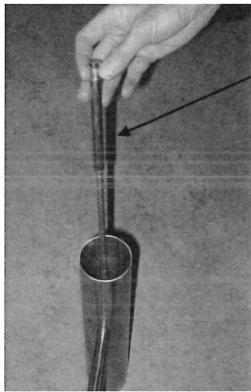
**Figure 2: The leg components**

2) Fit the legs onto the tips of the 'Y' as shown in figure 2, below. The hole in the legs is biased towards one end – this shorter end should be facing up.

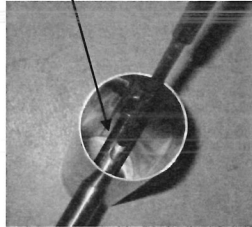


**Figure 3: Assembling the legs**

**3)** Next, slide one tube down each of the long bolts. Then drop one bolt/tube assembly into each leg, making sure to fit it through the hole on each end of the 'Y' bars. See figure 3.



Slide a tube on each bolt and then insert the bolt into the leg and through the hole at the end of the 'Y'



**Figure 4: Fitting the legs bolts.**

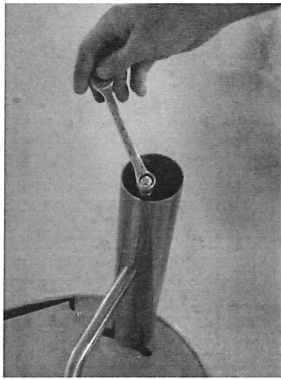
**4)** Lift the leg assembly onto the pads on the base of the wheel. The leg bolts locate into the **outer** threaded holes of the leg pads. A little grease on the threads will aid assembly.



**Figure 5: Fitting the legs onto the wheel.**

**5)** Using a 13mm (1/2") spanner, tighten the three leg bolts alternatively until they are firm and the legs are secure. Make sure that the legs have located over the pads on the base of the wheel and the legs are very rigid before fitting the three plastic feet.

**Hint:** Extra plastic feet may be stacked on to adjust the height of the wheel. Each foot increases the height by 20mm (3/4"). It is advised to limit the feet to three per leg.

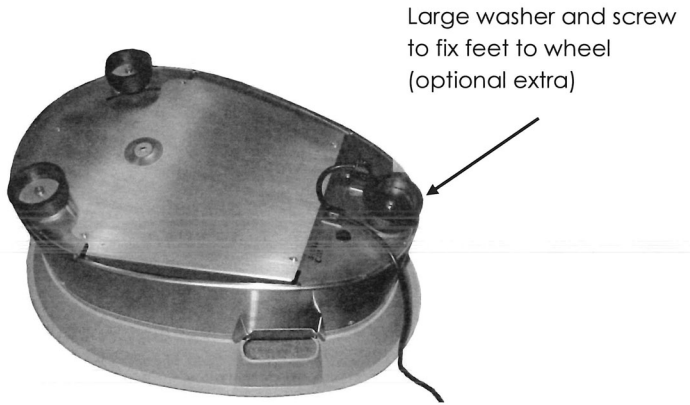


**Figure 6: Tightening leg bolts and fitting plastic foot.**

**Fitting rubber feet for table-top / floor operation.**

The wheel may be fitted with the three plastic feet as shown below using large stainless steel washers and screws, which are available as an optional extra.

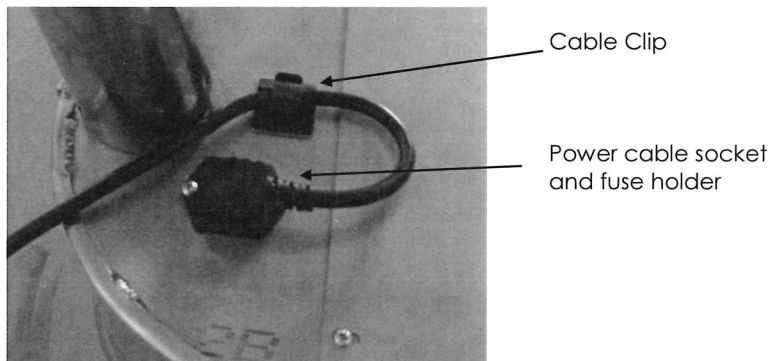
As with the sit down configuration, extra plastic feet may be stacked one on the other to adjust the height of the wheel.



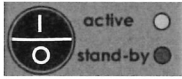
**Figure 7: Rubber feet fitted for low profile configuration.**

**Fitting the power cord.**

Firmly, fit the power cord supplied into the socket located near the rear leg. Next clip the cord into the cable clip as shown in figure 7.



**Figure 8: Securing the power cord with the cable clip.**



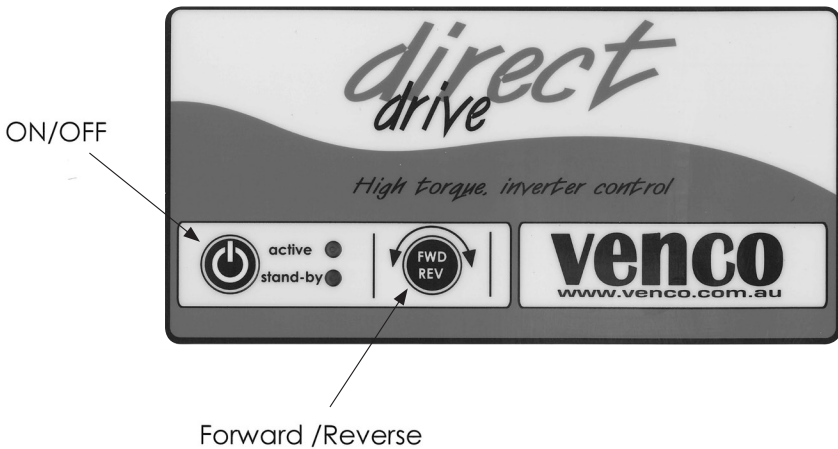
### Turning the Direct-Drive on

Plug the wheel into a correctly rated power outlet. **Note correct voltage and amperage on the sticker located on the base of the wheel.**

**Note:** It is recommended to use a surge protected power supply to protect your wheel in the event of any power spikes or surges.

Once the wheel is plugged into a power outlet a beep will sound and the red stand-by light should glow. When in **STAND-BY** mode the wheel uses a negligible amount of power due to its energy efficient design.

Press the **on/off** button once to put the wheel into **ACTIVE** mode, indicated by the green light.



**Figure 9: The Control touch-pad**



### **Changing direction**

The rotation direction may be changed **whenever the wheel is stationary.** Press the FWD/REV button once – a beep will sound to signal this has been recorded. This will become the standard direction until the button is pressed again – even if the wheel is turned off or un-plugged.

## **MAINTENANCE**

The Venco Direct Drive wheel has been designed for very low maintenance hence there are no user serviceable parts that need periodic attention.

### **Cleaning**

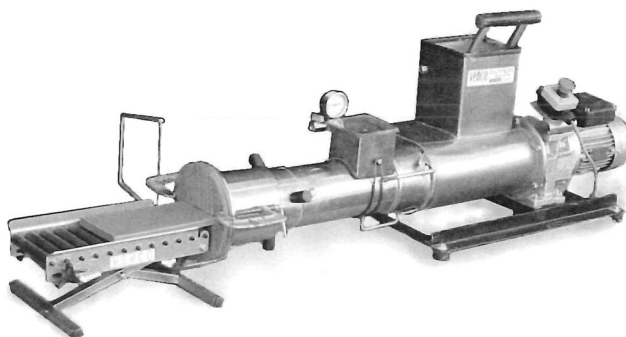
The entire wheel and including the touch pad can be cleaned using a soft, damp cloth. A gentle detergent may also be used if required. The stainless steel may be cleaned with a household polish such as Mr Sheen or any stainless steel polish.

**CAUTION:** *Do not hose down or soak the wheel/foot pedal with water.  
Disconnect the wheel from the power outlet before cleaning the wheel.*

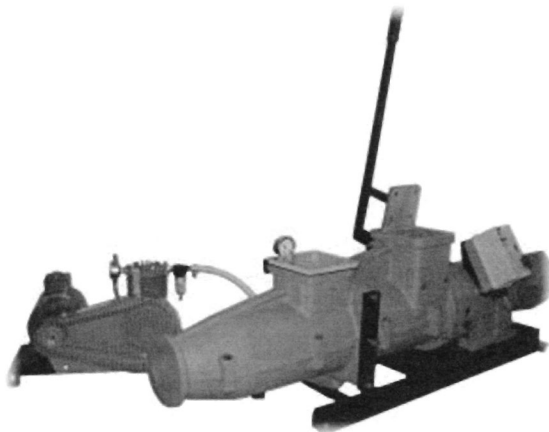


*Other ceramics equipment available from Venco*

**SUPER**  
*twin*  
modular system



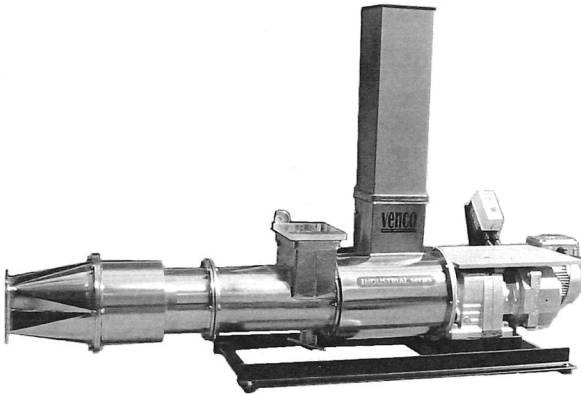
Super twin all stainless steel mixing, blending,  
extruding de-airing pugmill



75mm, 87mm and 100mm (3", 3.5", 4")  
de-airing pugmill



All stainless steel hand operated extruder



All stainless steel, high capacity, de-airing Pugmill  
with mechanical variable speed drive.

212 or 262mm (8.5" or 10: barrel)

Up to 4000ka/hr (8.800lb/hr)

*VENCO - World renowned for quality and reliability*

**Notes**

---

---

---

---

---

---

---

---

---

---

---

---

---

---

---

---

---

---

---

---

---

---

---

---

## **Venco Products**

29 Owen Road Kelmscott, Western Australia 6111

Ph: +61 8 9399 5265 Fax : +61 8 9497 1335

Email: [info@venco.com.au](mailto:info@venco.com.au)

**[www.venco.com.au](http://www.venco.com.au)**

# **venco**

**[www.venco.com.au](http://www.venco.com.au)**